

# Design of a Pelton Turbine for a Specific Site in Malawi

Sylvester William Chisale<sup>1,\*</sup>, Justice Stanley Mlatho<sup>2</sup>, Egide Manirambona<sup>3</sup>,  
Sylvester Richard Chikabvumbwa<sup>4</sup>

<sup>1</sup>Department of Applied Studies, Malawi University of Science and Technology, Thyolo, Malawi

<sup>2</sup>Department of Physics, University of Malawi, Chancellor College, Zomba, Malawi

<sup>3</sup>Faculty of Engineering Sciences, University of Burundi, Bujumbura, Burundi

<sup>4</sup>Department of Civil Engineering, University of Malawi, The Polytechnic, Blantyre, Malawi

## Email address:

[schisale@must.ac.mw](mailto:schisale@must.ac.mw) (S. W. Chisale), [smlatho@cc.ac.mw](mailto:smlatho@cc.ac.mw) (J. S. Mlatho), [egimanm@gmail.com](mailto:egimanm@gmail.com) (E. Manirambona),

[sylvechika@gmail.com](mailto:sylvechika@gmail.com) (S. R. Chikabvumbwa)

\*Corresponding author

## To cite this article:

Sylvester William Chisale, Justice Stanley Mlatho, Egide Manirambona, Sylvester Richard Chikabvumbwa. Design of a Pelton Turbine for a Specific Site in Malawi. *International Journal of Sustainable and Green Energy*. Vol. 9, No. 3, 2020, pp. 65-72.

doi: 10.11648/j.ijrse.20200903.12

**Received:** September 18, 2020; **Accepted:** October 5, 2020; **Published:** October 22, 2020

---

**Abstract:** Malawi's poor electrification rate can be improved through the maximum utilization of available renewable energy resources. Malawi has several rivers which can be utilized for electricity generation. However, most rivers such as Lichenya are not utilized to its full capacity. This paper presents the theoretical designing of a pelton turbine for Lichenya River in Malawi for maximum generation of electricity. Hydropower plants can either be impoundment, diversion or pumped storage type. The turbine used for any type of plant depends on the available head and river flow rate. The hydraulic turbines are classified into impulse turbines and reaction turbines. Pelton turbine is under impulse turbines and are usually associated with very high head and low discharges with low specific speeds. Additionally, Pelton turbine is simple to manufacture, are relatively cheap, and have good efficiency and reliability. The river flow data for Lichenya River were collected from the Ministry of Irrigation and Water Development in Malawi. The design flow of 3.2 m<sup>3</sup>/s for the river was determined from the data. The river is within the catchment area of 62.3 km<sup>2</sup> and gross head of 304 m. The calculation of dimensions were carried out with the aid of EES software and spreadsheet. The designed turbine can generate 8067 kW of power with a turbine hydraulic efficiency of 95.4%. The detailed dimensions of the bucket, runner, penstock, and nozzle are presented. Therefore, this study can be the best guideline for further energy developments on Lichenya River in Malawi.

**Keywords:** Hydraulic Turbine, River Flow, Turbine Dimensions, Pelton Turbine, Head

---

## 1. Introduction

Malawi compared to other Southern African Development Community (SADC) countries has the lowest electricity access rate. The country has electrification rate of 12.7% mostly in urban households in the cities of Blantyre, Lilongwe, Mzuzu, and Zomba. Rural and urban electrification are estimated at 3.9% and 48.7%, respectively. Grid electricity is unreliable due to inadequate generation capacity and outdated transmission and distribution lines resulting in frequent power outages and load shedding. Therefore, more effort is needed towards energy projects particularly renewables which are more sustainable [1, 2]. Mulanje Electricity Generating

Agency (MEGA), supported by Mulanje Renewable Energy Agency (MuREA) and Practical Action is utilizing Lichenya river for micro-hydro scheme for nearby communities [3]. However, the river is not utilized to its full capacity. This paper presents the designing of a pelton turbine for Lichenya River in Malawi for maximum generation of electricity.

### 1.1. Hydropower Plant

Hydropower plant technologies are mainly classified into three main types: impoundment (dam), diversion, and pumped storage. Globally, impoundment is a widely used technology and are usually large hydropower plants. This technology utilizes a dam to store water for controlled generation. A

diversion (run-of-river) technology divert a portion of a river through a canal or penstock. This type hydropower plant may not require a dam, however, it has limited flexibility to follow peak variation in power demand. A pumped storage hydropower technology utilises a small storage reservoir with a system for pumping water back into the reservoir after it has been released through the turbine, thus “re-using” the same water to generate electricity. This is usually used during periods of high electrical demand. [4].

### 1.2. Types of Turbine

Hydraulic turbine is defined as an energy converter that converts potential and kinetic energy of water into mechanical energy. Turbines are typically classified into impulse and reaction turbine [5]. Hydropower turbine are site specific and they generally depend on head and river flow for the location. In reaction turbines, the runner is completely submerged in water while impulse turbine’s runner operates outside water. Pressure casing is utilized in

reaction turbine while in impulse turbine the inside pressure is the same as atmospheric pressure hence casing is used to control splashing. Reaction turbine is designed to ensure pressure differences across them hence rotation of the runner. On the contrary, impulse turbines uses its nozzles to convert low velocity water into a high speed jet which hit blades of the turbine hence rotation [6].

Pelton turbine is a special type of axial flow impulse turbine with horizontal shaft where the buckets are mounted around the periphery of the wheel [7]. In this turbine, the flow of water jet is tangential to the runner as shown in Figure 1 and the water jets hit the buckets with kinetic energy. This type of turbine is best suited at a very high head and low river flow with low specific speeds. During operation of this turbine, the inlet and outlet is at atmospheric pressure. These turbines are simple to manufacture, are relatively cheap and have good efficiency and reliability [8, 9]. Figure 1 shows the main components of a Pelton turbine.

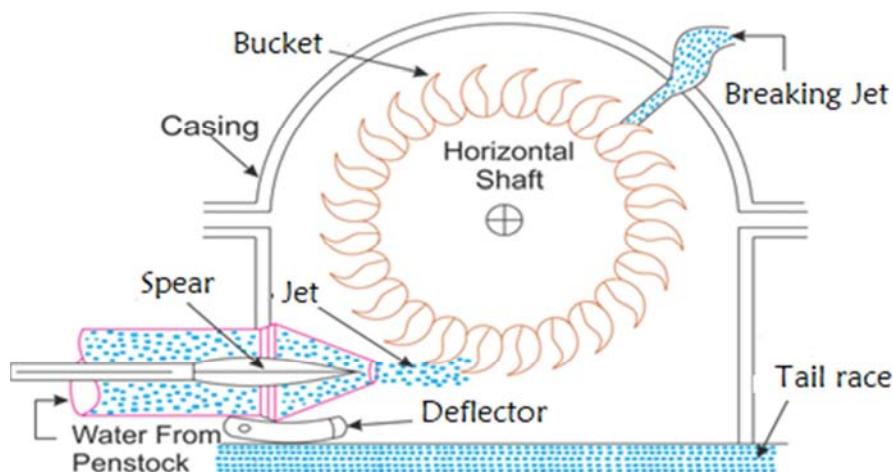

Figure 1. Main components of a Pelton turbine.

A spear needle inside the nozzle is responsible for controlling the amount of water hitting the buckets. The spear moves towards the nozzle to reduce water flow and vice-versa if the spear is moves in reverse which is done by a programmed system [10]. Water exits the nozzles at high velocity towards the buckets to a wheel. The runner has buckets on the periphery and they are equally spaced as shown in Figure 1. A bucket is defined as a hemispherical cup with a splitter at the middle in order to split the water jet into equal part. The surface of the bucket must be smooth to reduce friction. The buckets are made of strong metals such as bronze, cast-steel, cast-iron, stainless steel. A Pelton turbine has a casing made of cast-iron or fabricated steel plates. The main function of casing is shielding to minimize mechanical losses due to environmental disruptions. Additionally, casing prevent water splashes and ensure that water is directed into tailrace. In case of emergency or when you want to stop the turbine, breaking jet is applied at the back of the bucket to completely stop the turbine [11].

### 1.3. Friction

Friction greatly affect the efficiency of a turbine. Reduced friction improves the turbine’s output power. The efficiencies of the turbine can be classified as hydraulic efficiency, mechanical efficiency and volumetric efficiency. Hydraulic efficiency is defined at the ratio of power given by water to the runner of a turbine to the power supplied by the water at the inlet of the turbine. The power at the inlet of the turbine is higher as power that goes on decreasing as the water flows over the buckets. *Mechanical Efficiency* is the ratio of the power available at the shaft of the turbine to the power delivered to the runner. The power delivered to the runner is reduced due to mechanical losses. *Volumetric Efficiency* is the ratio of the volume of the water actually striking the runner to the volume of water supplied to the turbine. The volume of the water striking the runner of a turbine is slightly less than the volume of water supplied to the turbine. Some of the volume of the water is discharged to the tail race without striking the runner of the turbine [12].

## 2. Required Parameters for Pelton Turbine Design

### 2.1. Lichenya River

In Malawi, rainy season begins in November and Lichenya river receives fluctuating water levels with more waters in rainy season and nearly dry during dry season. In March the average flow reached  $42.82 \text{ m}^3/\text{s}$  while in October

it reached  $2.08 \text{ m}^3/\text{s}$  as shown in Figure 2. The average river discharge for Lichenya River were obtained from Ministry of Irrigation and Water Development, Malawi Government. The river discharge was measured at a period of 42 years from 1960 to 2002. However, due to some missing data the most recent dataset without missing data for the year 2001 was chosen. Figure 2 shows average river discharge for the year 2001.

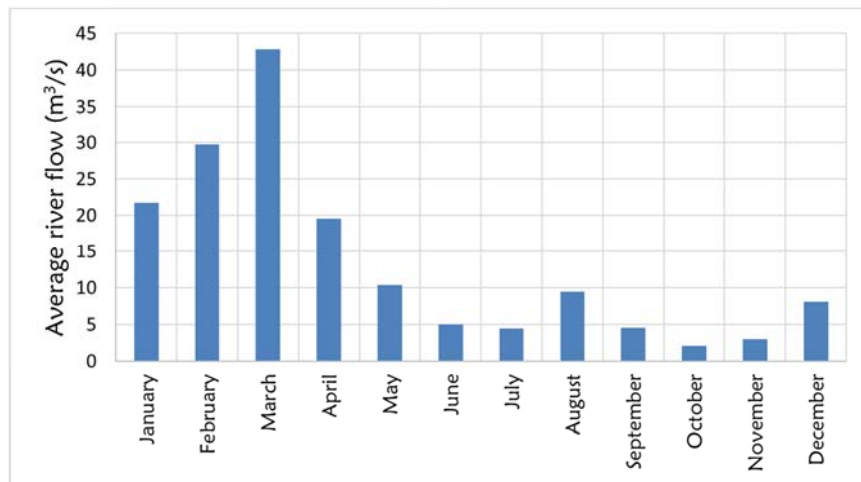

Figure 2. Lichenya River Discharge for 2001.

Lichenya River is within the catchment area of  $62.3 \text{ km}^2$  with head of 304 m [13]. Figure 3 shows monthly discharge of the river against the percentage availability in a year. The system was designed to operate 90% time of the year which gives a volume flow rate of  $3.2 \text{ m}^3/\text{s}$  in order to carry out

maintenance works. However, residual flow was assumed to be 2% of the design flow for environmental reasons. Therefore, the design flow for the system was estimated as  $3.14 \text{ m}^3/\text{s}$ . The pipe head loss was estimated to be 6%.

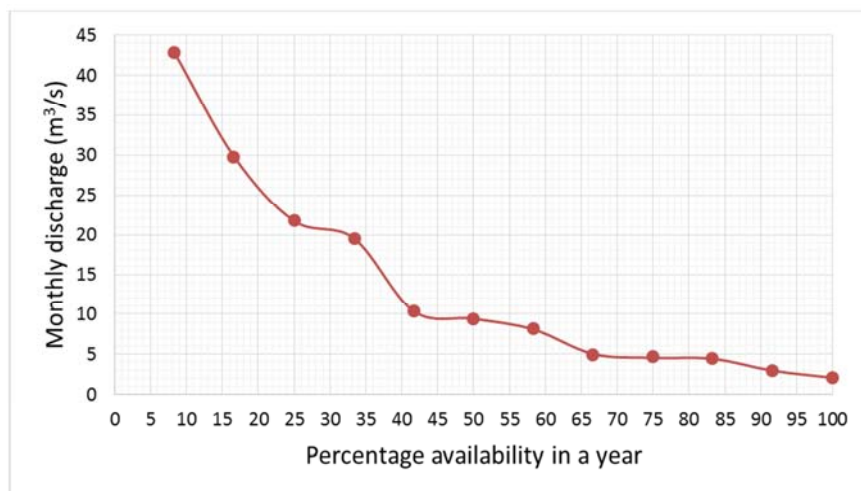

Figure 3. Determination of design flow for Lichenya River.

### 2.2. Suitable Turbine Type-turbine Selection

Turbine in hydropower plants are site specific because they depend on net head and flow rate of river [14]. The suitable type of turbine can be selected from Figure 4 depending on net head and flow rate. Lichenya River's head and flow rate of 304 m and  $3.14 \text{ m}^3/\text{s}$  are within the range of pelton turbine

type, hence pelton turbine type is selected for Lichenya River.

## 3. Design Calculations for the Turbine

The design of a pelton turbine involved mathematical calculation which uses different coefficients, constants and

other known parameters for design purpose. Table 1 shows the parameters that were used in this design.

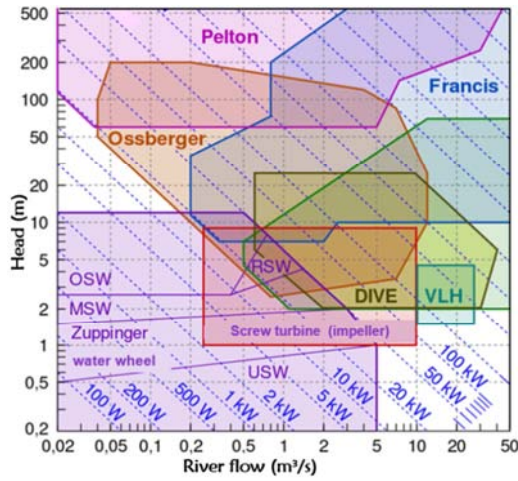

Figure 4. Turbine selection chart [14].

Table 1. Input coefficients and known parameters.

Symbol	Description	Dimension	Units
$F_c$	Friction factor acted upon by bearings	1.2	-
$g$	Gravity acceleration constant	9.81	$m/s^2$
$K_{wm}$	Bulk water modulus	$2.1 \times 10^9$	$N/m^2$
$L_{pt}$	Length of penstock between intake and turbine	1000	m
$M_p$	Modulus of penstock material	$2.8 \times 10^9$	-
$n_p$	Manning factor of penstock	0.011	-
$\psi$	Bucket roughness coefficient	0.98	-
$Q$	River discharge	3.14	$m^3/s$
$H_g$	Gross head	304	m
$\rho_w$	Density of water	1000	$Kg/m^3$
$\rho_m$	Density of bucket material (Cast steel)	8050	$Kg/m^3$
S. F	Safety factor to prevent water hummer effect (>2.5)	2.8	-
$\theta$	Deflection angle between bucket and jet ( $160^\circ$ - $170^\circ$ )	160	Degree
$x$	Ratio of runner tangential velocity to jet velocity	0.46	-
$C_n$	Nozzle (jet) discharge coefficient	0.98	-

The design procedure of the Pelton turbine which is used in micro hydropower generation can be systematic. Firstly, this involves preparing the site data of power plant.

The input power of a turbine is given by eq. 1, where the net head ( $H_n$ ) for a given site is given by eq. 2 and  $H_{tl}$  is the head loss due to friction as water flows through penstock, gates and valves.

$$P_{ti} = \rho_w \times g \times C_n^2 \times H_n \times Q_t \quad (W) \quad (1)$$

$$H_n = H_g + H_{tl} \quad (m) \quad (2)$$

The specific speed ( $N_s$ ) is given by eq. 3 which is a correlation between the number of jets ( $n_j$ ) and the net head ( $H_n$ ). However, depending on the number of jets ( $n_j$ ), the total flow is divided to each nozzle as shown in eq. 4. The turbine speed ( $N$ ) given in (r. p. m) can be obtained using eq.

5 which depends on turbine input power ( $P_{ti}$ ), net head and specific speed.

$$N_s = 85.49 \times \sqrt{n_j} / H_n^{0.243} \quad (3)$$

$$n_j = Q_t / Q_n \quad (4)$$

$$N = N_s \times H_n^{5/4} / \sqrt{P_{ti}} \quad (\text{r. p. m}) \quad (5)$$

Another important parameter to calculate is the runner circle diameter,  $D_r$ . The runner circle diameter ( $D_r$ ) can be obtained using eq. 6 where  $x$  is the ratio of runner tangential velocity to nozzle or jet velocity assumed to equal to 0.46 because at maximum efficiency  $x$  between 0.46 to 0.47 and jet velocity ( $V_j$ ) is given by eq. 7. When no load is available it's run-away speed can be given by eq. 8 [5, 6].

$$D_r = \frac{60 \times x}{\pi N} \times V_j \quad (m) \quad (6)$$

$$V_j = C_n \times \sqrt{2 \times g \times H_n} \quad (m/s) \quad (7)$$

$$N_r = \frac{60 \times V_j}{\pi D_r} \quad (\text{r. p. m}) \quad (8)$$

In a Pelton turbine, nozzle dimensions are obtained using jet diameter which is directly related to nozzle diameter. From the relationship of water flow rate through each nozzle ( $Q_n$ ) and nozzle area ( $A_j$ ) in eq. 9 and eq. 10, Nozzle or jet diameter ( $D_j$ ) can be obtained [5]. Detailed dimensions for the nozzles were calculated and presented as shown in Table 5 and Figure 10 [15].

$$Q_n = V_j \times A_j \quad (m^3 \cdot s^{-1}) \quad (9)$$

$$A_j = \pi \times \frac{D_j^2}{4} \quad (m^2) \quad (10)$$

The divergence of the jet can be prevented by aligning the nozzle exits close to the Pelton runner. Thus, the space between the nozzle and runner should be calculated using eq. 11 which is 5% of the runner circle diameter, plus an extra 3 mm clearance. The distance between nozzle and bucket can be obtained using eq. 12.

$$X_{nr} = 0.05 \times D_r + D_t \quad (m) \quad (11)$$

$$X_{nb} = 0.625 \times D_r \quad (m) \quad (12)$$

The bucket dimensions can be calculated in relation to nozzle diameter,  $D_j$ . The dimensions can be between maximum and minimum values. Bucket width,  $B$ , depends on jet diameter,  $D_j$ , can be obtained using the relationships in Table 2. Detailed dimensions for the bucket were calculated and presented as shown in Table 4 and Figure 9 [16]:

Table 2. Bucket width formulae.

	Minimum value	Maximum value
Bucket width, $B$	$2.8 \times D_j$	$4 \times D_j$

The number of buckets for the turbine must be calculated so that no water particle is lost. Additionally, number of buckets arrangement must minimize the risks of detrimental interactions between the out flowing water particles and adjacent buckets. The number of buckets and length of the moment arm of bucket was obtained using eq. 13 and eq. 14 respectively. The radius of bucket center of mass to center of runner was obtained using eq. 15.

$$n_b = 15 + \frac{D_r}{(2 \times D_j)} \quad (13)$$

$$L_{ab} = 0.195 \times D_r \quad (\text{m}) \quad (14)$$

$$R_{br} = 0.47 \times D_r \quad (\text{m}) \quad (15)$$

Other important dimensions to consider include volume and mass of a bucket. The volume and mass of a bucket were calculated using eq. 16 and eq. 17 respectively.

$$V_b = 0.0063 \times D_r^3 \quad (\text{m}^3) \quad (16)$$

$$M_b = \rho_m \times V_b \quad (\text{kg}) \quad (17)$$

For Penstock design, the thickness of penstock made from PVC was chosen by determining the potential water hammer effect. The thickness of penstock ( $t_p$ ) and diameter of a penstock ( $D_{pt}$ ) were obtained using eq. 18 and eq. 19 [5].

$$t_p = \left[ \left( \frac{D_{pt} + 508}{400} \right) + 1.2 \right] \times 10^{-3} \quad (\text{m}) \quad (18)$$

$$D_{pt} = 2.69 \times \left( n_p^2 \times Q_t^2 \times \frac{L_{pt}}{H_g} \right)^{0.1875} \quad (\text{m}) \quad (19)$$

The surge pressure ( $H_s$ ) was obtained using eq. 20. Where  $\Delta V$  and  $V_w$  are given by eq. 21 and eq. 22. Additionally, total head,  $H_t$ , was obtained using eq. 23.

$$H_s = V_w \times \frac{\Delta V}{g} \quad (\text{m}) \quad (20)$$

$$V_w = \sqrt{\frac{1}{\rho_w \times \left( \frac{1}{K_{wm}} + \frac{D_{pt}}{M_p \times t_p} \right)}} \quad (\text{m. s}^{-1}) \quad (21)$$

$$\Delta V = \frac{Q}{n_j \times A_p} \quad (\text{m. s}^{-1}) \quad (22)$$

$$H_t = H_g + H_s \quad (\text{m}) \quad (23)$$

In case of emergency, a deflector system is required to protect the generator in case a load circuit failure, and the generator rotates at over speed. The force in each deflector, the required force in each deflector were obtained using eq. 24 and eq. 25. Additionally, the torque acting on the deflector arm and required torque acting on the deflector arm were obtained using eq. 26 and eq. 27.

$$F_d = \rho_w \times Q_{n \times V_j} \quad (\text{N}) \quad (24)$$

$$F_{dr} = F_d \times S.F \quad (\text{N}) \quad (25)$$

$$T_d = F_{dr} \times R_d \quad (\text{N. m}) \quad (26)$$

$$T_{dr} = T_d \times F_c \quad (\text{N. m}) \quad (27)$$

The efficiency of a turbine indicates the performance of a turbine during operation. The efficiency of a turbine is affected by losses in the system. The turbine hydraulic efficiency can be obtained by comparing input power to the turbine (eq. 28) and output power developed by the turbine (eq. 29). Where  $\phi = 180^\circ - \theta$  and  $\theta$  ranges from  $160^\circ$  to  $170^\circ$ . Thus, turbine hydraulic and maximum hydraulic turbine efficiency were obtained using eq. 30 and eq. 31 respectively.

$$P_{ti} = \frac{\rho_w \times Q_t \times V_j^2}{2} \quad (\text{W}) \quad (28)$$

$$P_{to} = \rho_w \times Q_t \times V_{tr} \times [(V_j - V_{tr}) \times (1 + \cos(\phi))] \quad (\text{W}) \quad (29)$$

$$\eta_{th} = \frac{P_{to}}{P_{ti}} \quad (30)$$

$$\eta_{th(max)} = \frac{[1 + \psi \times \cos(\phi)]}{2} \quad (31)$$

## 4. Results and Discussion

The calculation of pelton turbine dimension were carried out with the aid of EES software and spreadsheet. Table 2 shows the calculated dimensions of pelton turbine and some of the notable corresponding dimensions are shown in Figure 7.

Table 3. Calculated dimensions of a pelton turbine.

Symbol	Description	Dimensions	Units
Dj	Jet or nozzle diameter	0.11267	m
Dpt	Diameter of penstock connected to the turbine	0.9519	m
Dr	Runner (wheel) circle diameter	1.18	m
Dt	Deflector thickness	0.003	m
nb	Number of buckets	20.06	-

Symbol	Description	Dimensions	Units
$n_j$	Number of turbine nozzles	4	-
$R_{br}$	Radius of bucket center of mass to runner center	0.5547	M
$L_{ab}$	Length of bucket moment arm	0.2301	M
$M_b$	Mass of bucket	83.38	Kg
$A_j$	Jet or nozzle cross-sectional area	0.0107	$m^2$

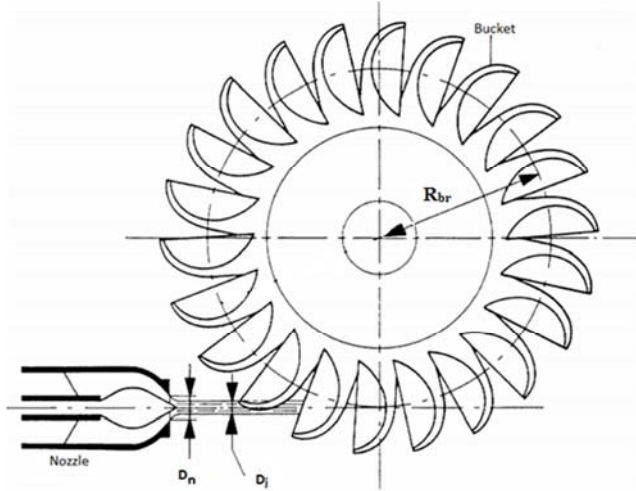

Figure 5. Dimensions of pelton turbine.

The design of pelton turbine also requires specific dimensions of buckets hence Table 4 shows the possible range of dimensions in relation to Figure 6 for this river site.

Table 4. Bucket dimensions.

	Formulae	Minimum value	Maximum value
M	$0.36 \times B$	0.117634	0.168048
L	$0.82 \times B$	0.267943	0.382776
S	$0.16 \times B$	0.052282	0.074688
E	$0.36 \times B$	0.117634	0.168048
A	$0.64 \times B$	0.209126	0.298752
B	Table 2	0.32676	0.4668

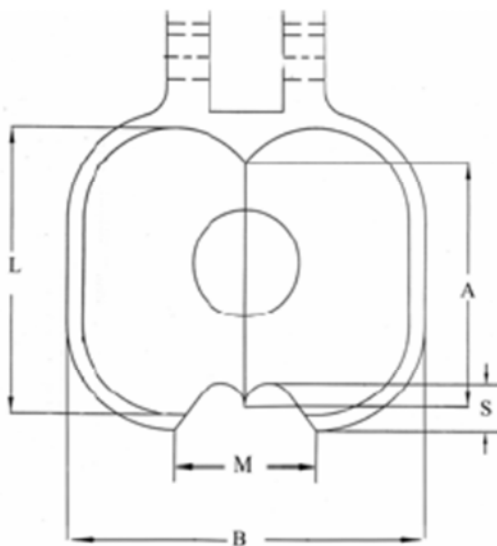

Figure 6. Bucket showing specific dimensions.

Table 5. Nozzle formulae [15] and calculated dimensions.

	Formulae	Minimum value	Maximum value
C	$0.63 \times D_j$	0.2059	0.2941
s	$1.35 \times D_j$	0.4411	0.6302
x	$0.503 \times D_j$	0.1644	0.2348
d	$0.63 \times D_j$	0.2059	0.2941
I	$3.17 \times D_j$	1.0358	1.4798
r	$0.705 \times D_j$	0.2304	0.3291
R	$2.2 \times D_j$	0.7189	1.027
h	$0.6 \times D_j$	0.1961	0.2801
c	$0.05 \times D_j$	0.0163	0.0233
f	$1.13 \times D_j$	0.3692	0.5275

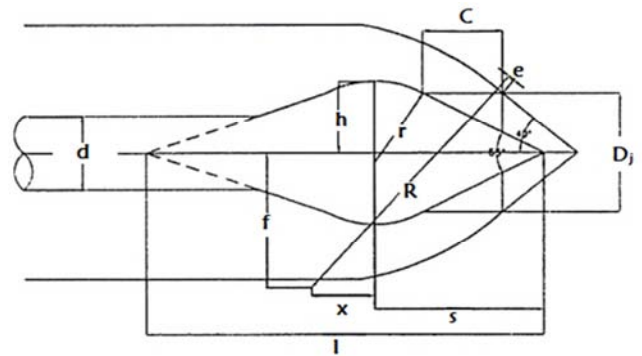

Figure 7. Calculated Dimensions for a Nozzle.

Table 6. Other calculated parameters.

Symbol	Description	Dimension	Units
Fd	Deflector force	57603	N
Fdr	Required deflector force	161289	N
Hn	Net head	285.8	M
Htl	Total head loss	18.24	M
N	Turbine (runner) speed	552.9	r. p. m
Nr	Turbine run-away speed	1187	r. p. m
Ns	Turbine specific speed	43.27	-
Hs	Surge pressure	12.16	m
Qn	Nozzle flow rate	3.14	$m^3/s$
Qt	turbine flow rate	3.14	$m^3/s$

The performance of the designed turbine was further assessed by calculating the input and output turbine power. Additionally, turbine hydraulic efficiency was computed. Table 7 gives a summary of performance of a turbine.

Table 7. Performance indicators of the designed turbine.

Symbol	Description	Dimension	Units
Pti	Turbine input power	8454	kW
Pto	Turbine output power	8067	kW
$\eta_{th}$	Turbine hydraulic efficiency	0.9543	-
$\eta_{thmax}$	Maximum turbine hydraulic efficiency	0.9604	-

This study was limited to 4 nozzles because of easy construction of the system. 4 nozzles aligned at 90 degree angles will produce balanced loads on the bearing and housing unit. However, number of jets for the turbine were varied from 1 to 10. From the results, shown in Table 8, as the number of jets increases, jet diameter,  $D_j$ , runner diameter,  $D_r$ , and mass

of the bucket decreases. Conversely, as the number of jets increases, the turbine (runner) speed,  $N$ , increases. Number of buckets,  $n_b$ , efficiency,  $\eta_{th}$ , and turbine output power remains constant. Table 8 gives the summary of some the effects of varying number of jets. Figure 8 shows variation of number of jets with mass of a bucket. Figure 9 shows variation of Head loss with Power output, Figure 10 shows variation of river flow with turbine speed and Figure 11 shows variation of river flow with power output.

**Table 8.** Effect of changing number of jets.

$n_j$	$D_j$ (m)	$D_r$ (m)	$M_b$ (kg)	$n_b$	$N$ (r. p. m)	$\eta_{th}$	$P_{to}$ (kW)
1	0.2334	2.361	667	20.06	276.4	0.9543	8067
2	0.1651	1.669	235.8	20.06	390.9	0.9543	8067
3	0.1348	1.363	128.4	20.06	478.8	0.9543	8067
4	0.1167	1.18	83.38	20.06	552.9	0.9543	8067
5	0.1044	1.056	59.66	20.06	618.1	0.9543	8067
6	0.09529	0.9637	45.39	20.06	677.1	0.9543	8067
7	0.08822	0.8922	36.02	20.06	731.4	0.9543	8067
8	0.08253	0.8346	29.48	20.06	781.9	0.9543	8067
9	0.07781	0.7868	24.71	20.06	829.3	0.9543	8067
10	0.07381	0.7465	21.09	20.06	874.1	0.9543	8067

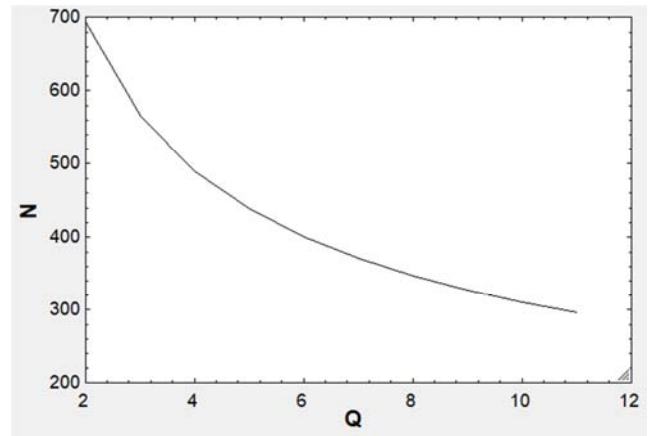

**Figure 10.** Variation of river flow with turbine speed.

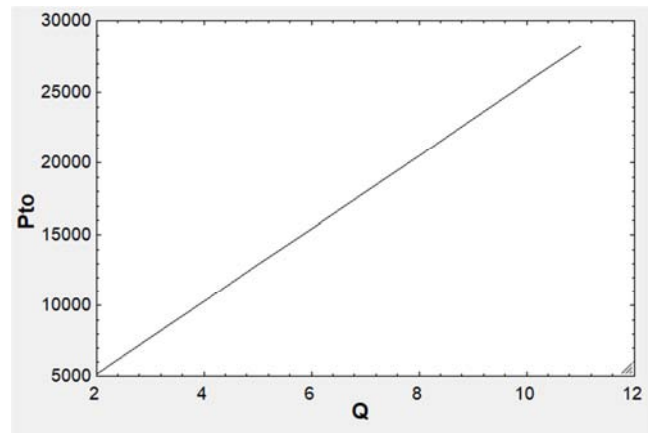

**Figure 11.** Variation of river flow with power output.

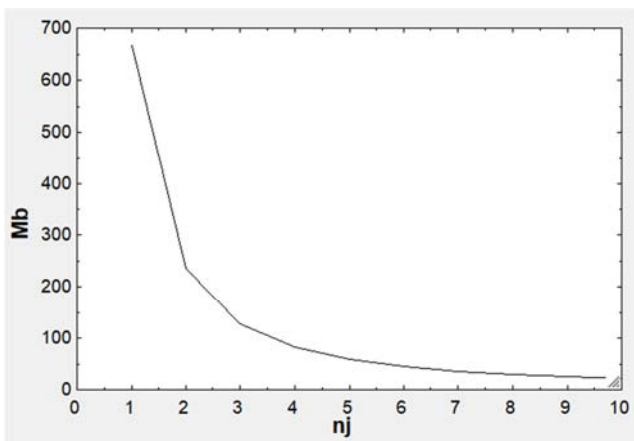

**Figure 8.** Variation of number of jets with mass of a bucket.

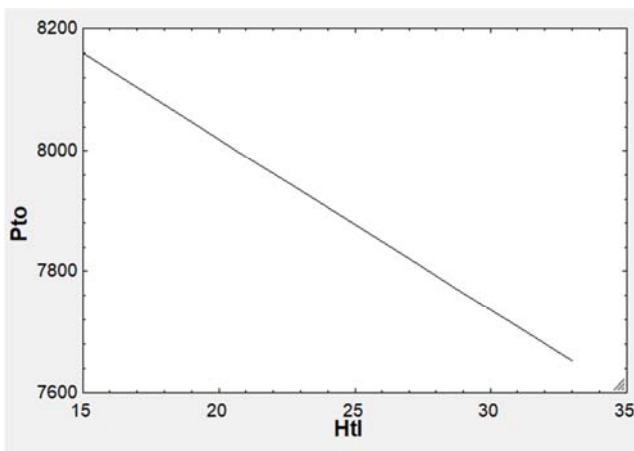

**Figure 9.** Variation of Head loss with Power output.

### 5. Conclusion

Turbine is one of the key components of hydropower plant to generate electricity. The output power of the turbine is site specific in relation to head and flow rate. An intake structure with trash rack channels water via a Penstock down to a turbine before the water released down- stream [17]. In a high head and low water flow, the turbine is typically Pelton type connected directly to a generator. Lichenya River has head of 304 m and flow of 3.14 m<sup>3</sup>/s which can exist 90% of the year. The designed turbine can generate 8067 kW of power with turbine hydraulic efficiency of 95.4%. For this site, detailed dimensions of bucket and nozzle for Pelton turbine have been presented. The bucket dimensions must be between maximum and minimum value with respect to jet diameter. Therefore, this study can be a guideline for further energy developments on Lichenya River in Malawi.

### Acknowledgements

The authors acknowledge the Ministry of Irrigation and Water Development for providing flow data for Lichenya River. The authors would further like to thank the blind reviewers who helped to improve the quality of the paper with their constructive criticism.

---

## References

- [1] JICA, "Sector position paper: Energy Sector," no. September 2019. JICA Malawi Office, pp. 2–6, 2020, (Online). Available: <https://www.jica.go.jp/malawi/english/activities/c8h0vm00004bpzlh-att/energy.pdf>.
- [2] S. W. Chisale, S. R. Chikabvumbwa, and L. Chisanu, "Assessment of Reservoir Based Hydropower System, a Case Study : Dwangwa River, Malawi," *J. Energy Res. Rev.*, vol. 5, no. 4, pp. 1–13, 2020, doi: 10.9734/JENRR/2020/v5i430151.
- [3] MEGA, "MEGA's Mini-Grid Technology." Mulanje Electricity Generation Agency, 2020, (Online). Available: <https://www.mega.mw/activities/technology>.
- [4] R. B. Alley, S. Blumsack, D. Bice, M. Feineman, and A. Millet, "Energy, Environment and our Future: Conventional Hydroelectric Dams." The Pennsylvania State University, 2020, (Online). Available: <https://www.e-education.psu.edu/earth104/node/1067#:~:text=There are three main types, river water in a reservoir>.
- [5] B. A. Nasir, "Design of high Efficiency Pelton Turbine for Micro-Hydropower Plant," *Int. J. Electr. Eng. Technol.*, vol. 4, no. 1, pp. 171–183, 2013.
- [6] P. V. M. Prajapati, P. R. H. Patel, and P. K. H. Thakkar, "Design, Modeling & Analysis of Pelton Wheel Turbine Blade," *Int. J. Sci. Res. Dev.*, vol. 3, no. 10, pp. 159–163, 2015.
- [7] A. K. Raja, A. P. Srivastava, and M. Dwivedi, *Power Plant Engineering*. New Delhi: New Age International (P) Ltd, 2006.
- [8] A. K. Minn, H. H. Win, and N. A. San, "Design of 225kW Pelton Turbine," *Int. J. Sci. Eng. Technol. Res.*, vol. 03, no. 24, pp. 4836–4842, 2014.
- [9] Z. M. Chan, "Design Calculation of Penstock and Nozzle for 5kW Pelton Turbine Micro Hydropower Plant," *Int. J. Trend Sci. Res. Dev.*, vol. 3, no. 5, pp. 1245–1247, 2019, (Online). Available: [www.ijtsrd.com](http://www.ijtsrd.com).
- [10] F. A. Ishola, O. O. Kilanko, A. O. Inegbenebor, T. F. Sanni, adebiyi A. Adelokun, and D. Adegoke, "Design and Performance Analysis of a Model Pico Size Pelton Wheel Turbine," *Int. J. Civ. Eng. Technol.*, vol. 10, no. May, pp. 727–739, 2019, (Online). Available: <http://www.iaeme.com/ijciet/issues.asp?JType=IJCIET&VType=10&IType=05>.
- [11] E. E. Mon, C. C. Khaing, and A. zaw Lynn, "Design, Construction and Performance Testing of 1 kW Pelton Turbine for Pico Hydro Power Plant," *Int. J. Sci. Eng. Appl.*, vol. 8, no. 07, pp. 192–196, 2019.
- [12] L. K. Gudukeya and C. Mbohwa, "Improving the Efficiencies of Pelton Wheel in Micro- Hydro Power Plants," in *Proceedings of the International Conference on Industrial Engineering and Operations Management*, 2017, pp. 1089–1100.
- [13] J. L. Taulo, R. W. Mkandawire, and K. J. Gondwe, "Energy Policy Research Baseline Study for Mulanje and Phalombe Districts," Mulanje, 2008.
- [14] M. Prodanović, A. Miltenović, and M. Nikodijević, "Determination of operating parameters of turbines for micro hydroelectric power plants for optimal use of hydropower," *IOP Conf. Ser. Mater. Sci. Eng.*, 2019, doi: 10.1088/1757-899X/659/1/012046.
- [15] K. Theint and L. Myo, "Design of Speed Control System for Pelton Turbine," *Int. J. Sci. Res. Publ.*, vol. 8, no. 7, pp. 312–319, 2018, doi: 10.29322/IJSRP.8.7.2018. p 7950.
- [16] Z. O. Than, N. Nyi, and C. C. Khaing, "Design Calculation of Pelton Turbine for 220 kW," *Int. J. Sci. Res. Publ.*, vol. 9, no. 7, pp. 218–224, 2019, doi: <http://dx.doi.org/10.29322/IJSRP.9.07.2019. P 9131>.
- [17] B. A. Nasir, "Design Consideration of Micro-Hydro-Electric Power Plant," *Energy Procedia*, vol. 50, pp. 19–29, 2014, doi: 10.1016/j.egypro.2014.06.003.